

Orhan Pamuk

Žena crvene kose

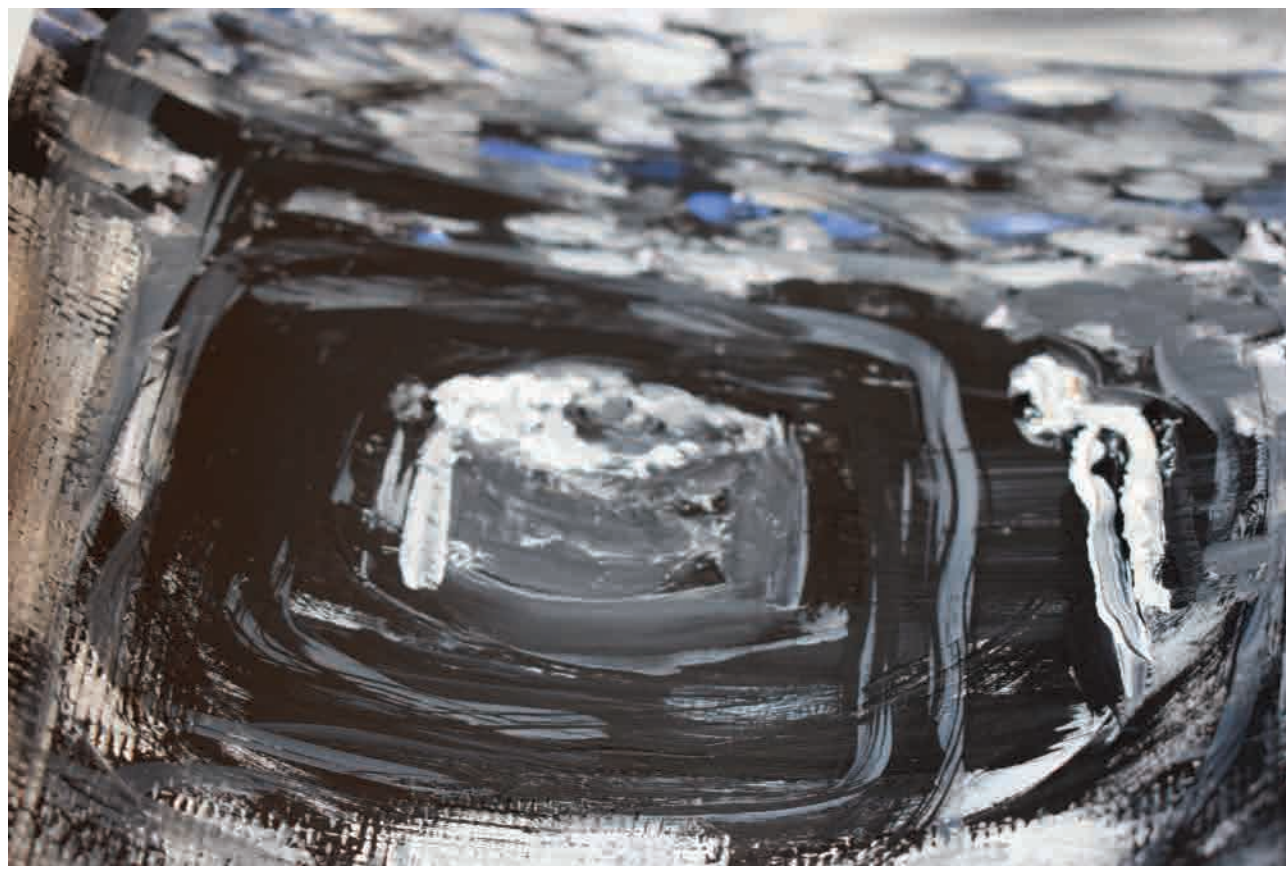

IDEJNE SKICE

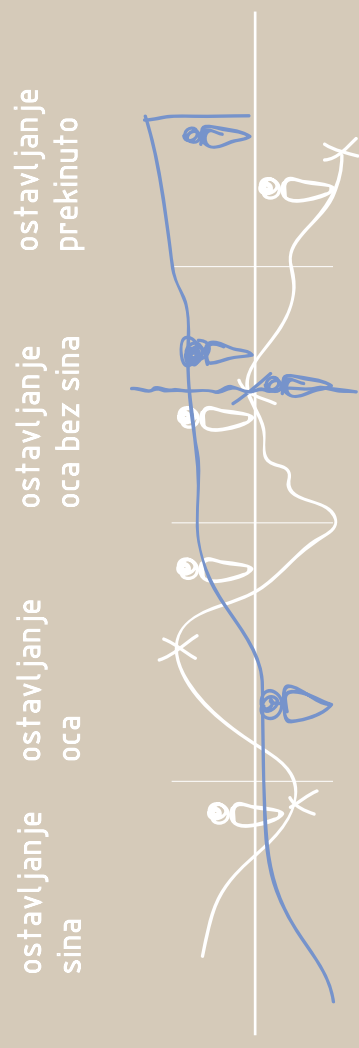

SKICA I ČINA

Majka sedi na klupi, uplakana. Čeka Džema. Džem posle nekog vremena dolazi i saznaje da je otac otišao. Razgovaraju o ocu. Džem je očajan i teško mu pada očev odlazak. Pričaju o budućnosti i Džemovom odlasku da kopa bunar.

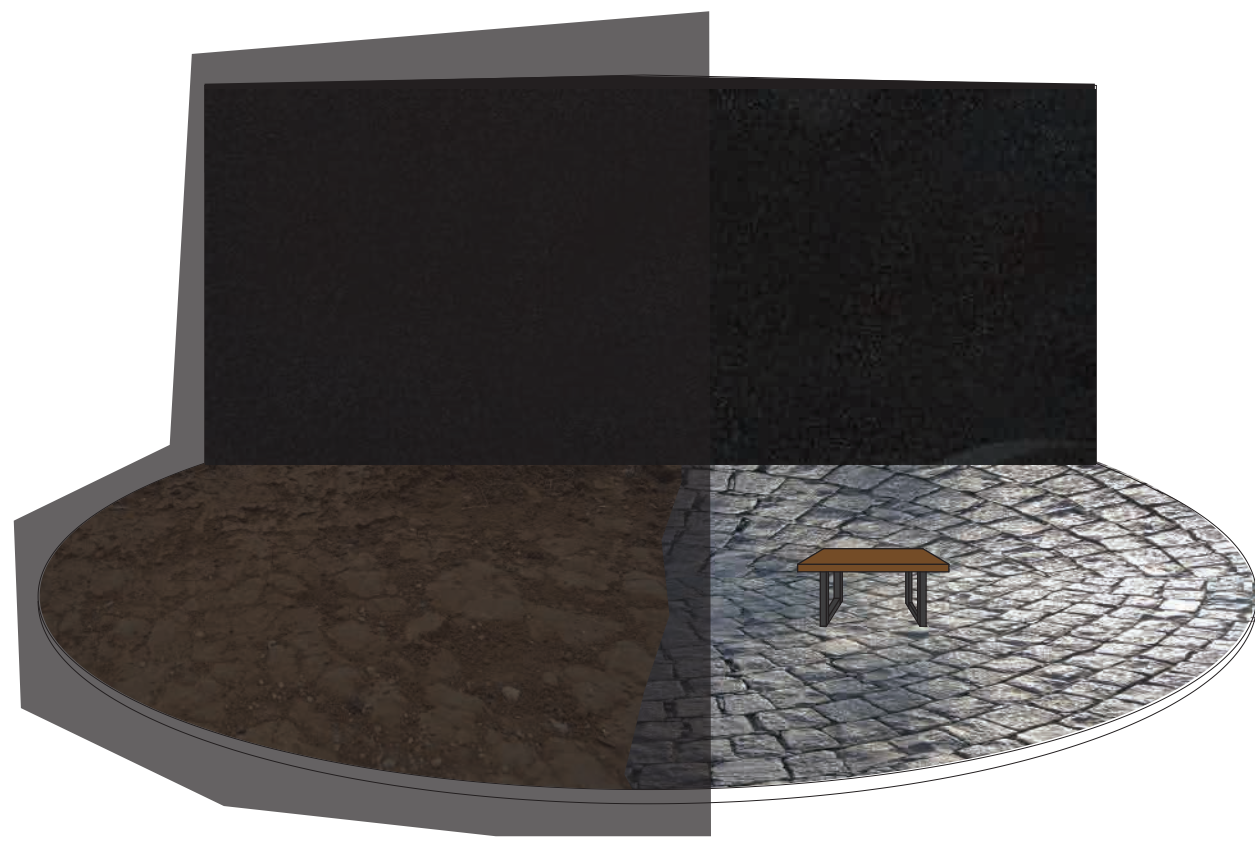

MAKETA

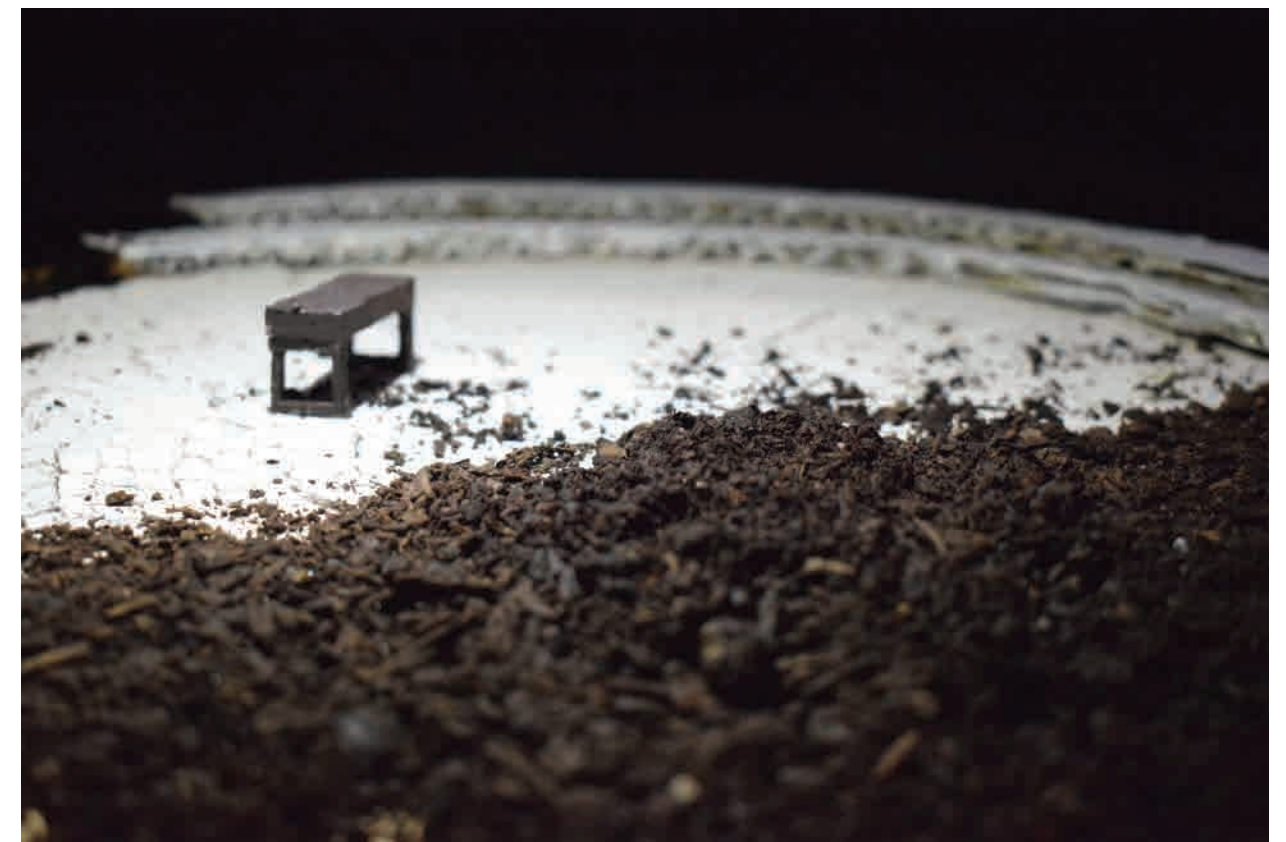

SKICA II ČINA

Džem i majstor Mahmut dolaze u Ongoren, na mesto gdeće kopati bunar. Upoznaju se, pričaju priče. Kopaju bunar. Majstor čeka Džema da se vrati od Žene crvene kose. Kasnije kofa pada, Džem ostavlja majstora u bunaru i odlazi.

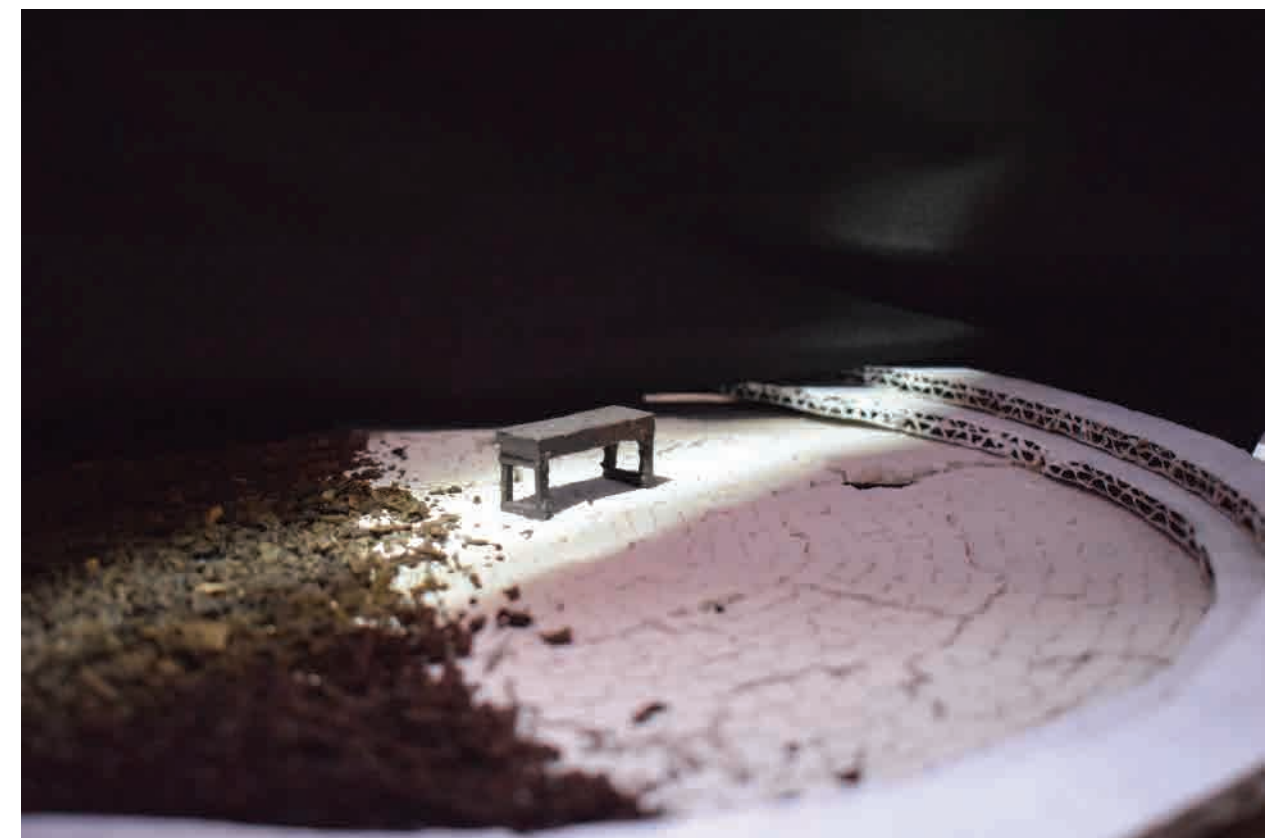
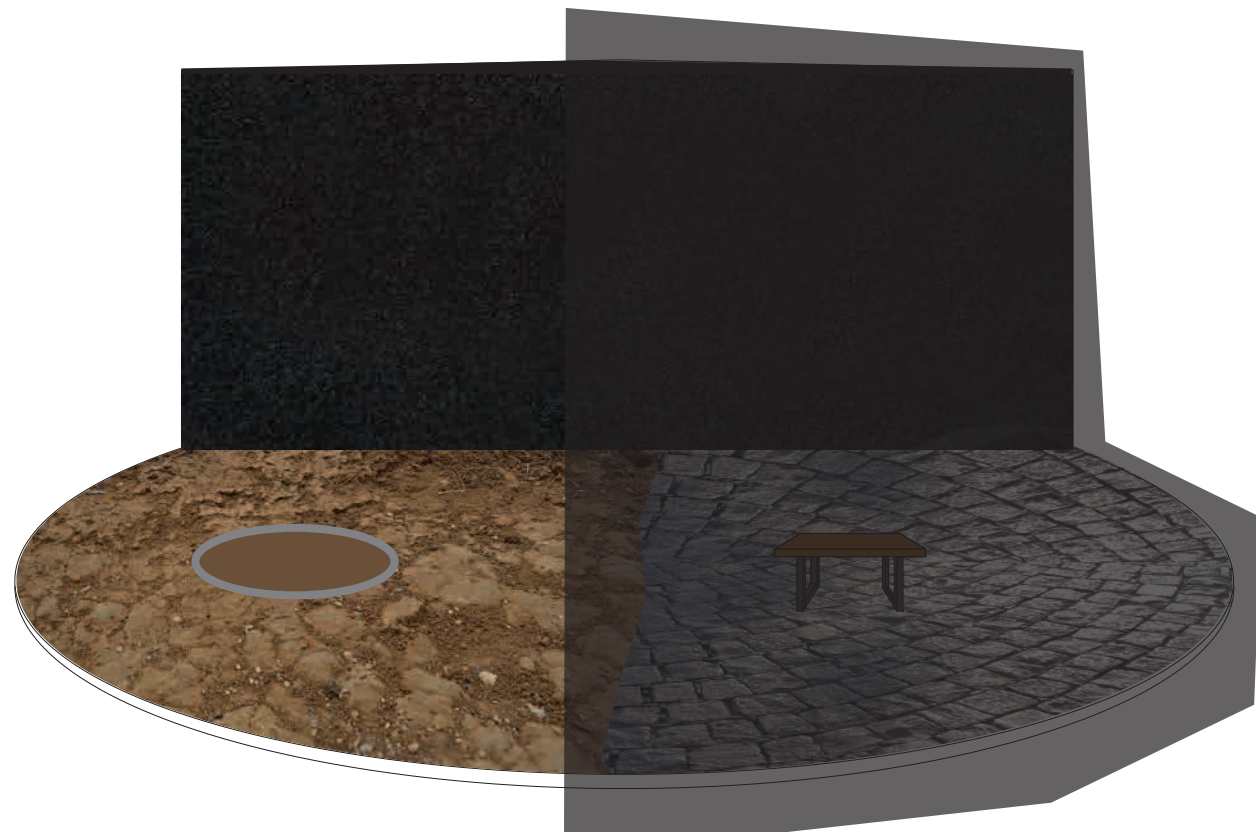

SKICA III ČINA

Džem pokušava da nastavi noramalan život, ali ga muči prošlost. Dobija pismo. Čita ga. Saznaje da ima sina. Razgovara sa advokatom o svojoj imovini. Odlučuje da ode u Ongoren.

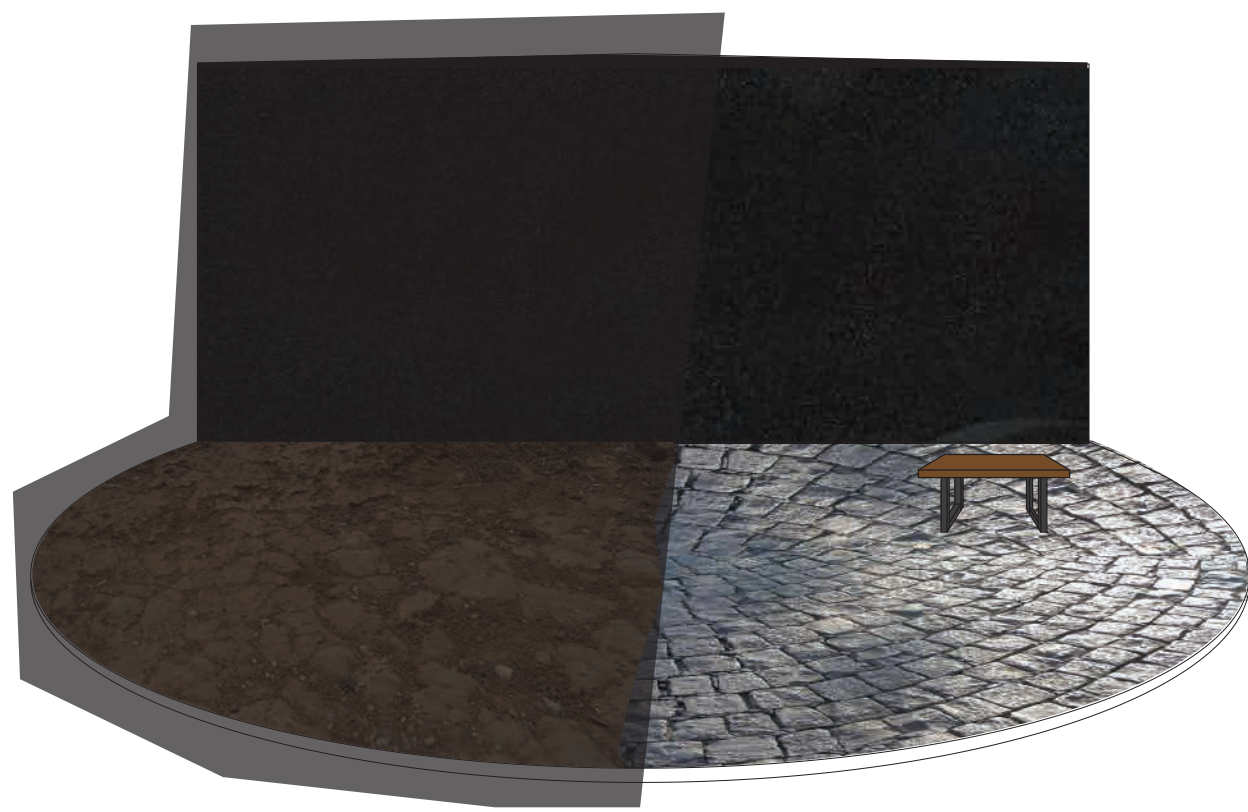

SKICA IV ČINA

Džem dolazi u Ongoren. Upoznaje Serhata, njih dvoje šetaju i pričaju. Posle nekog vremena Džem shvata da je Serhat Enver, da je on njegov sin. Džem vadi pištolj, sa kojim u borbi biva ubijen. Enver ostaje pored Džema ne beži.

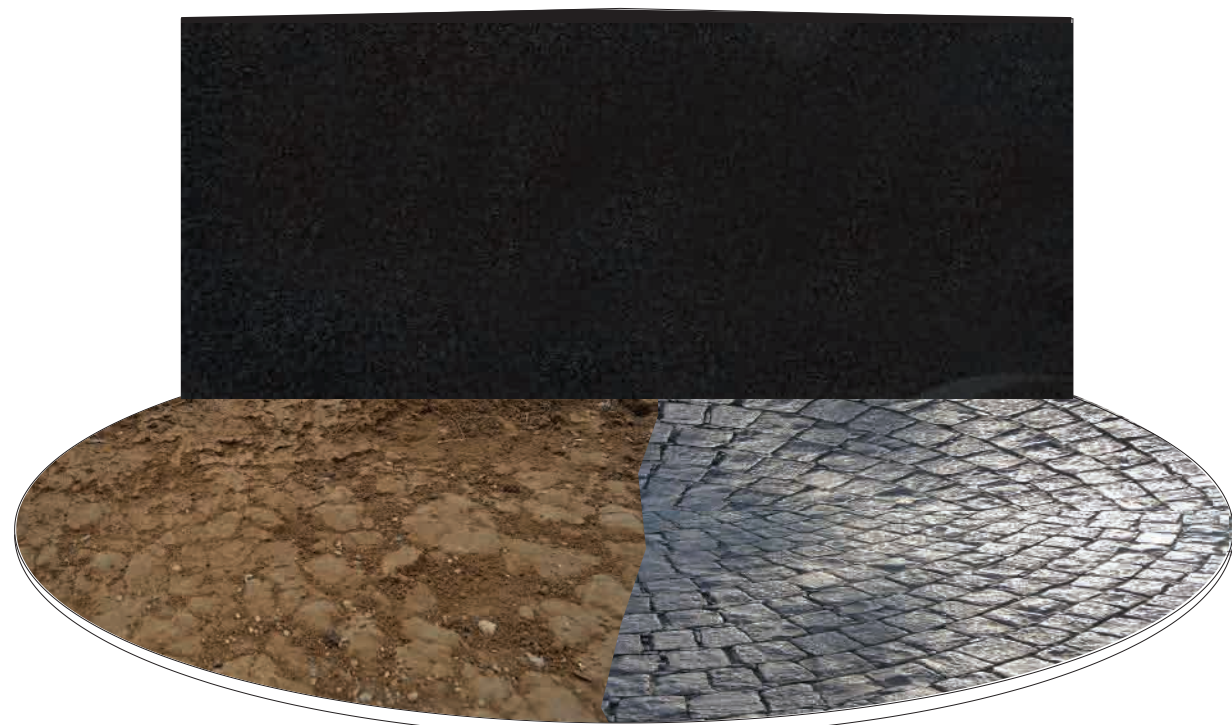

OSNOVA POZORNICE

I scena

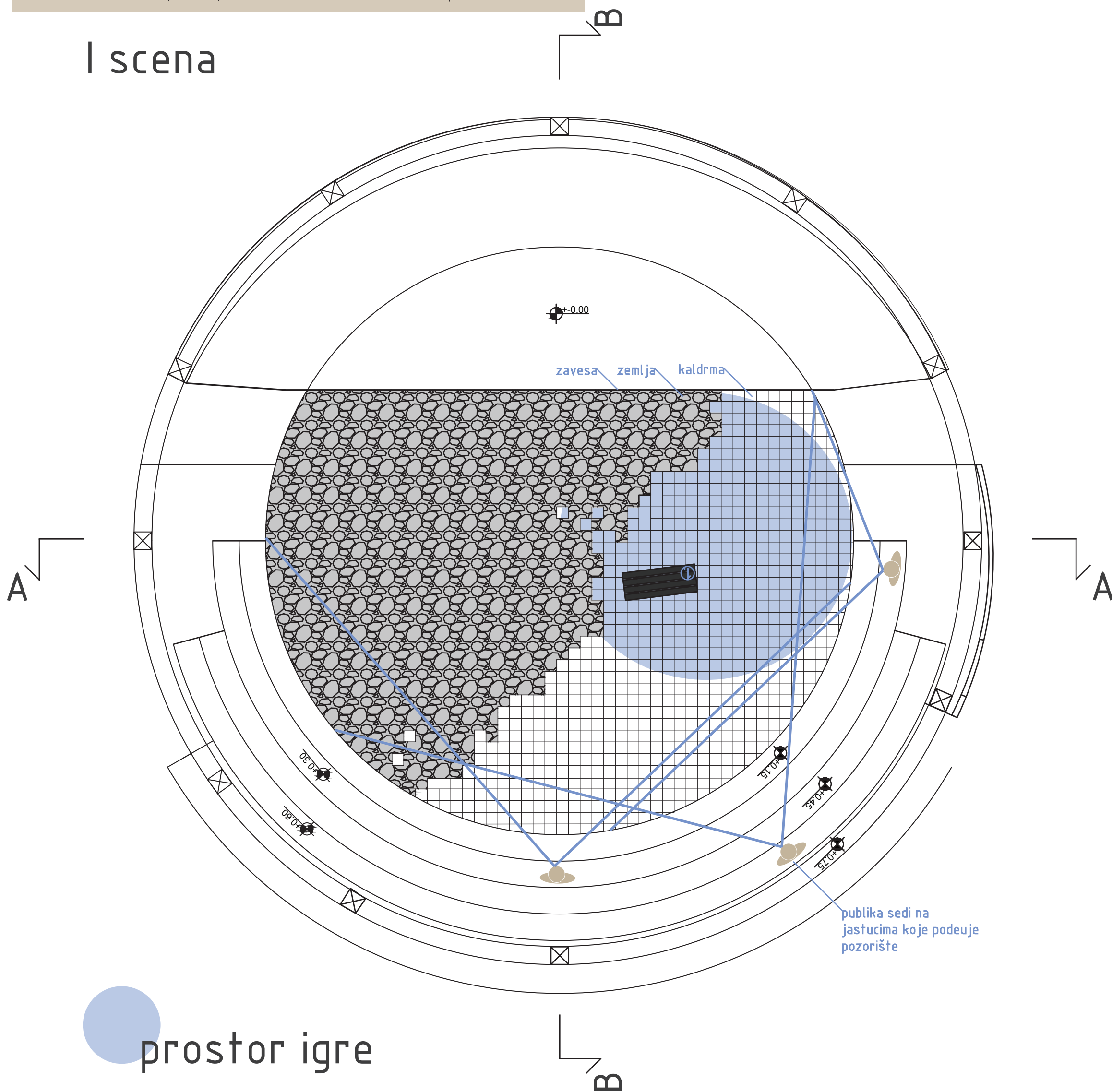

PRESEK POZORNICE

I scena
presek A - A

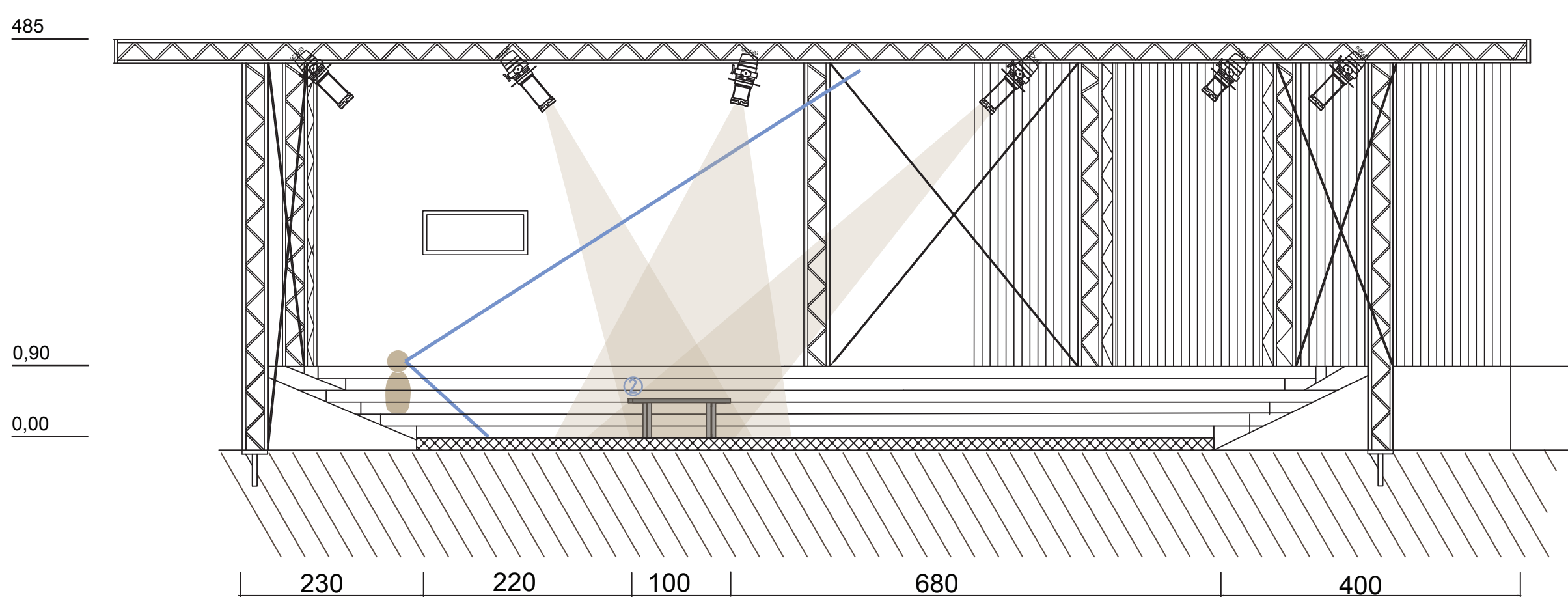

I scena
presek B - B

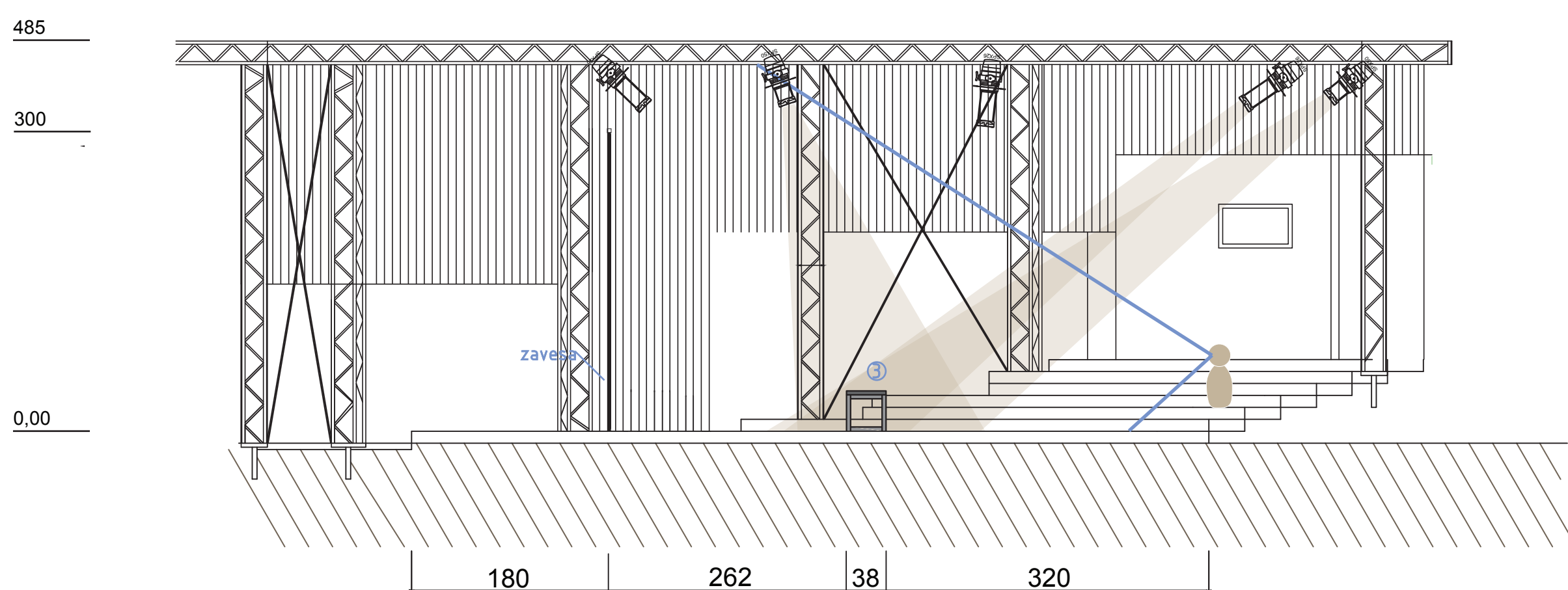

II scena

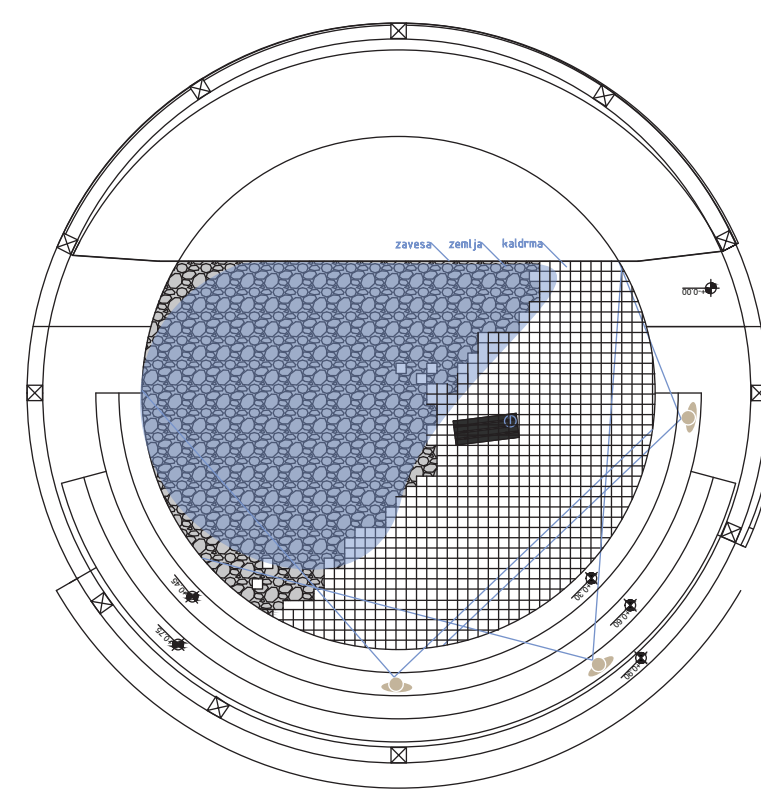

III scena

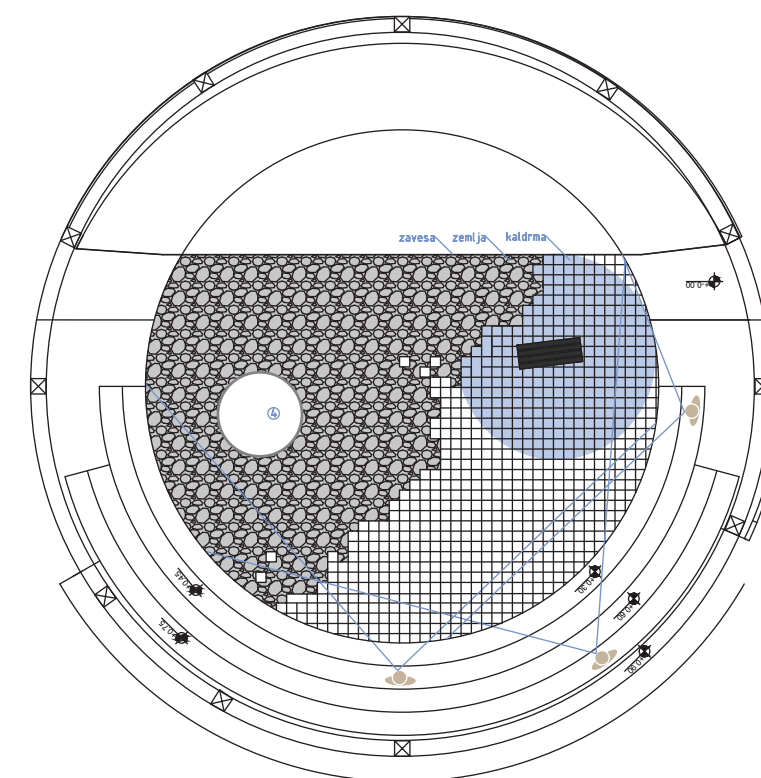

IV scena

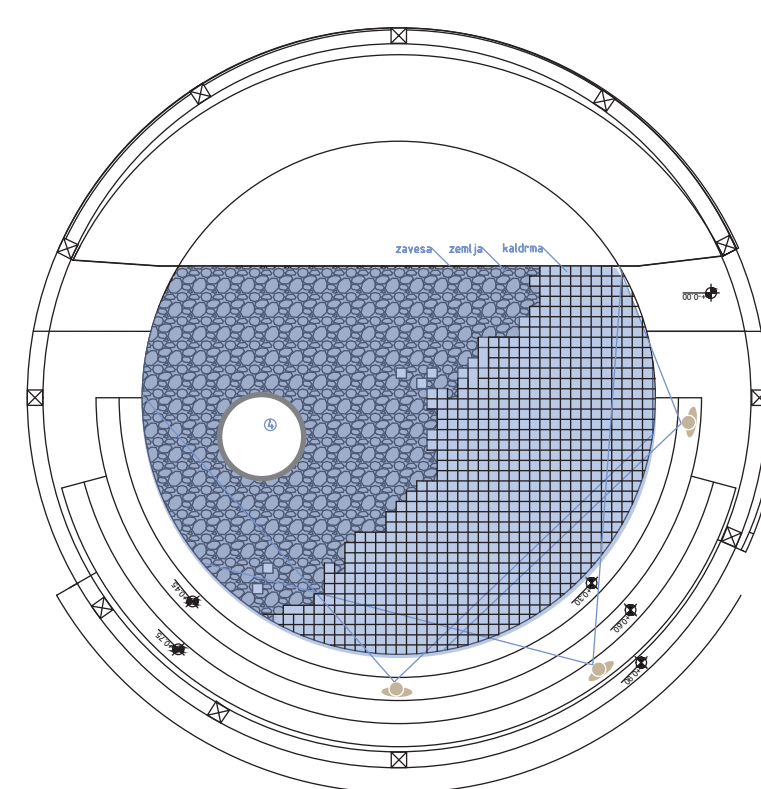

LEGENDA

- 1. klupa
- 2. klupa
- 3. klupa



LEGENDA - rasveta

Source Four Profil Spot 15 - 30 / 750 W

Source Four Frenel / 750 W

IV scena
presek B-B

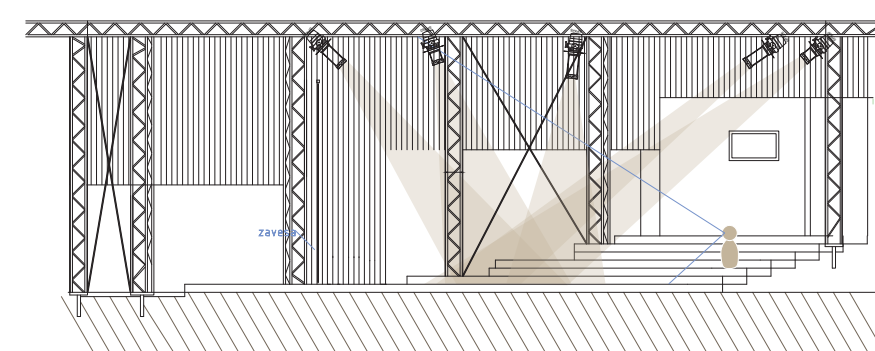
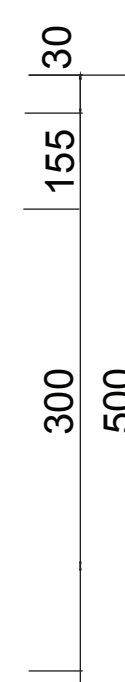

TEHNIČKA RAZRADA

klupa, R = 1:5

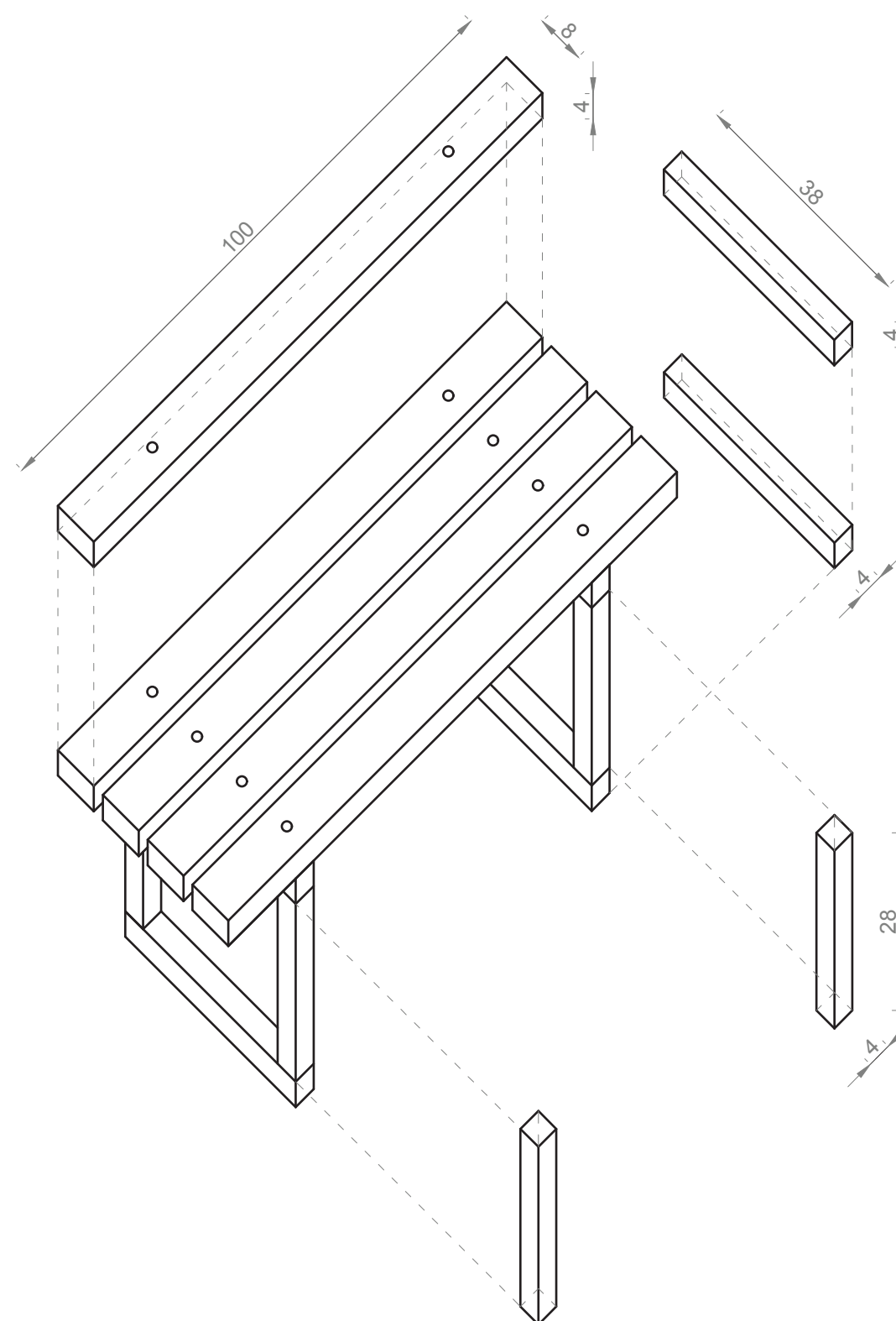
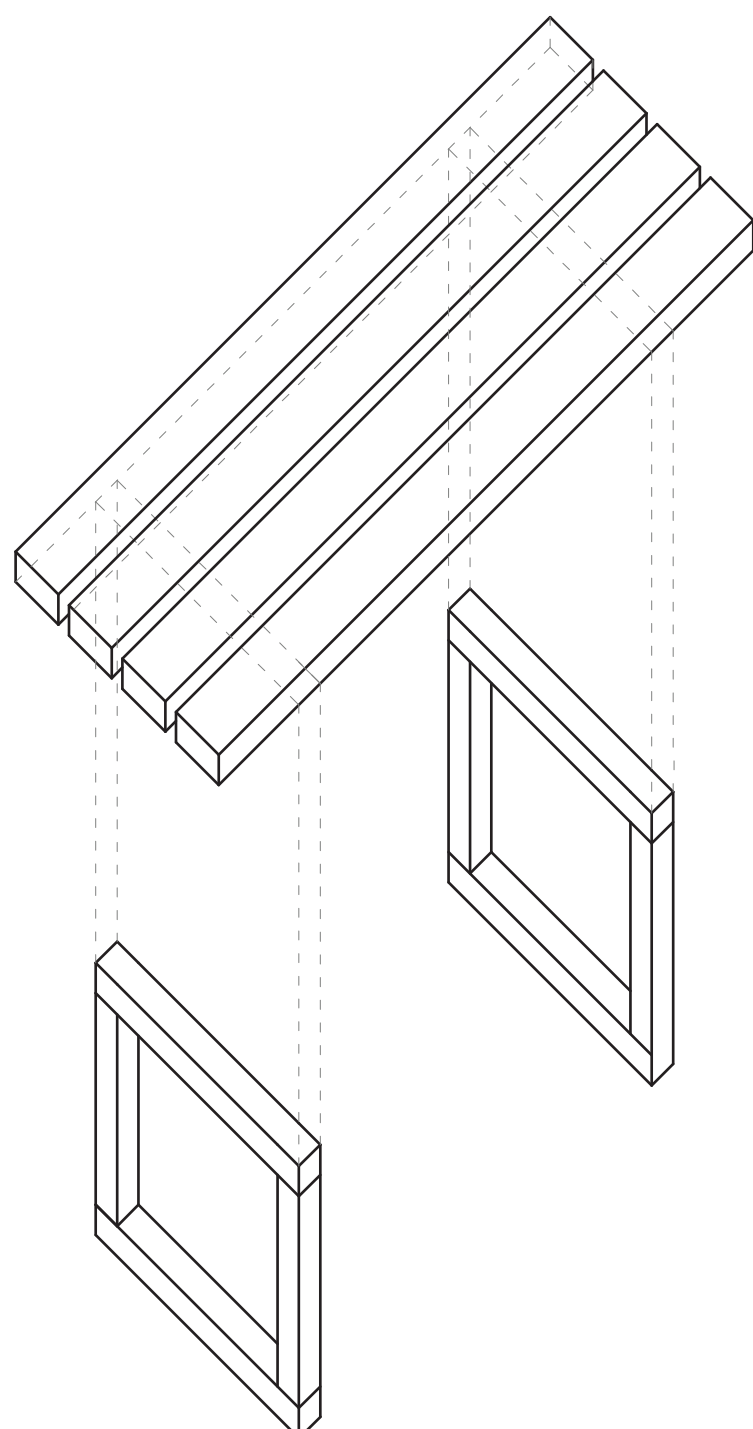
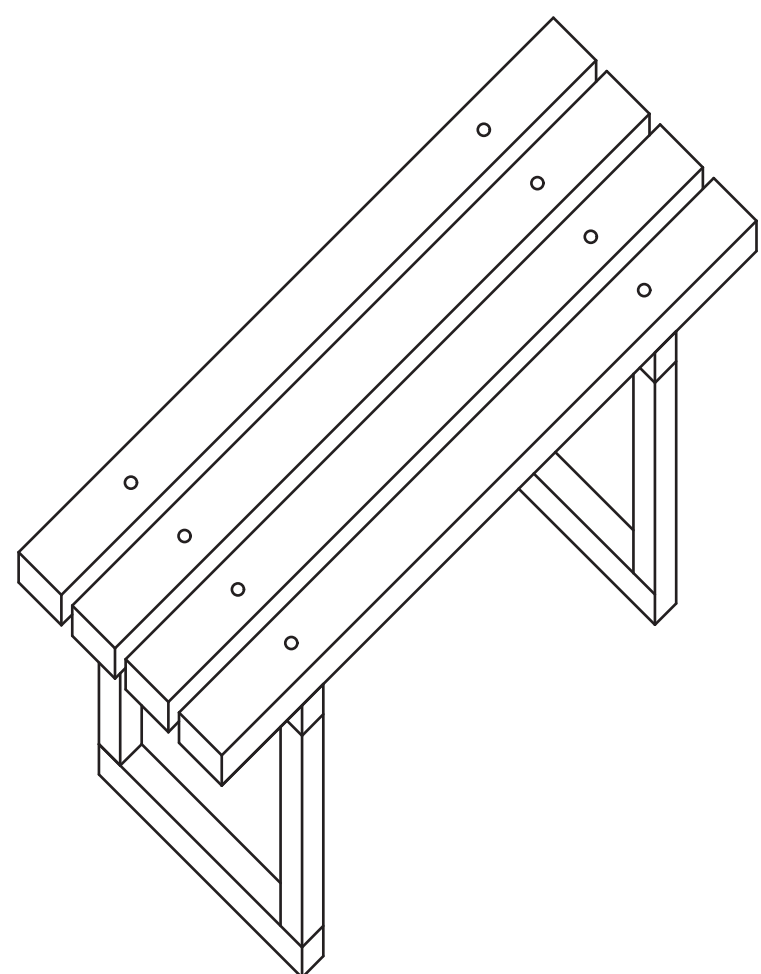

drvena klupa,
drvo jele,
ofarbana u braon

(opširnije u pregledu materijala i opreme)

zavesa, kačenje, R = 1:5

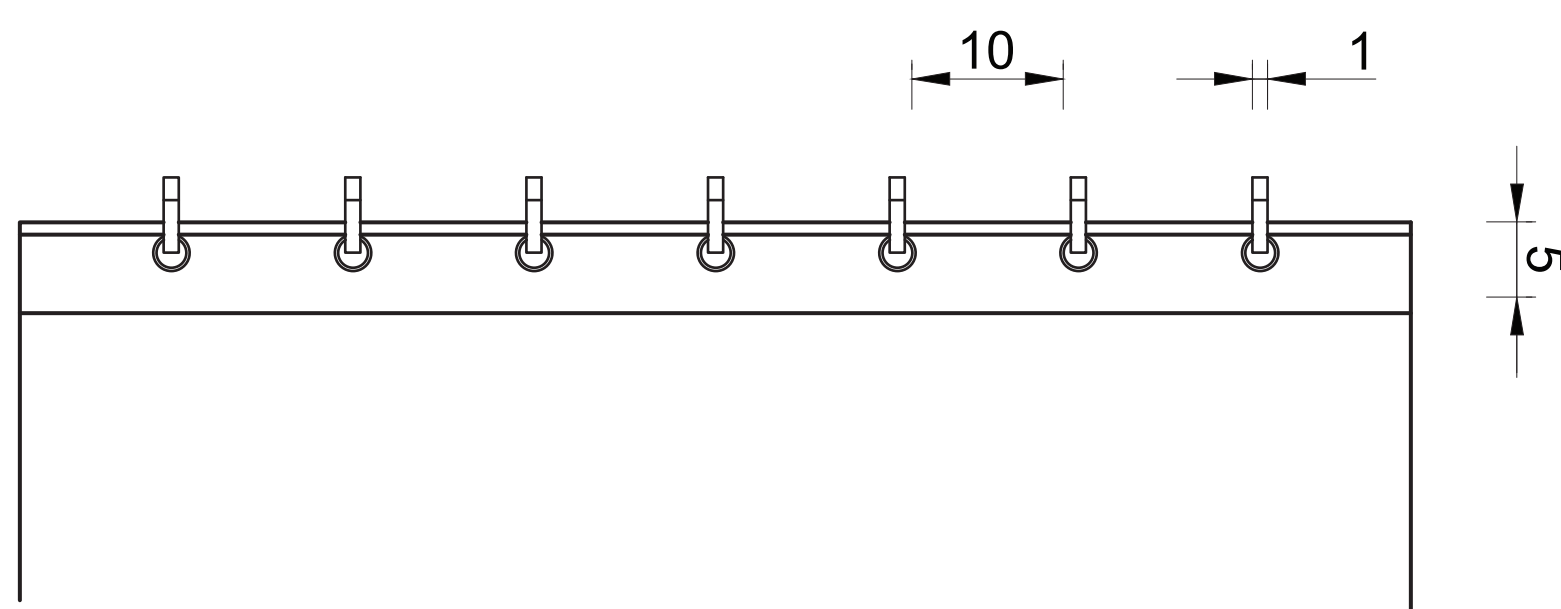

crno platno,
visine 3m, širine 15m
kačaljke postoje u pozorištu

(opširnije u pregledu materijala i opreme)

REKVIZITA

II scena
lopata
kofa



III scena
pismo



IV scena
pištolj
mobilni telefon



KOSTIM

kostim Džema, po činovima

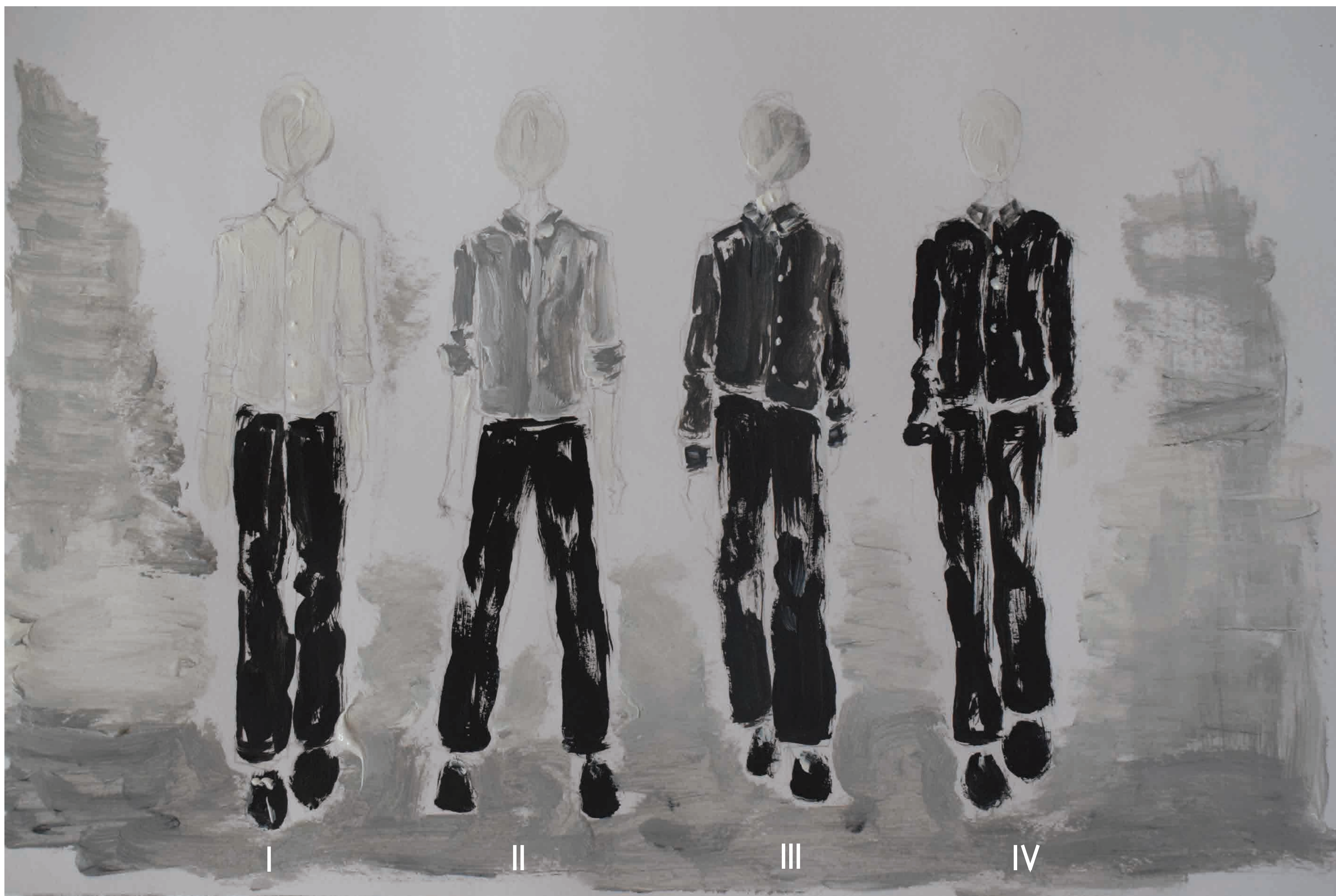

majka, Asuman,
I čin

advokat, Nedžati
III čin

sin, Envera,
IV čin

